

adicolor

atmosfere e colori di casa tua



EMOZIONE

VALORI

SOLUZIONI

INVESTIAMO
nel presente
per un **futuro**
di **SUCCESSO**

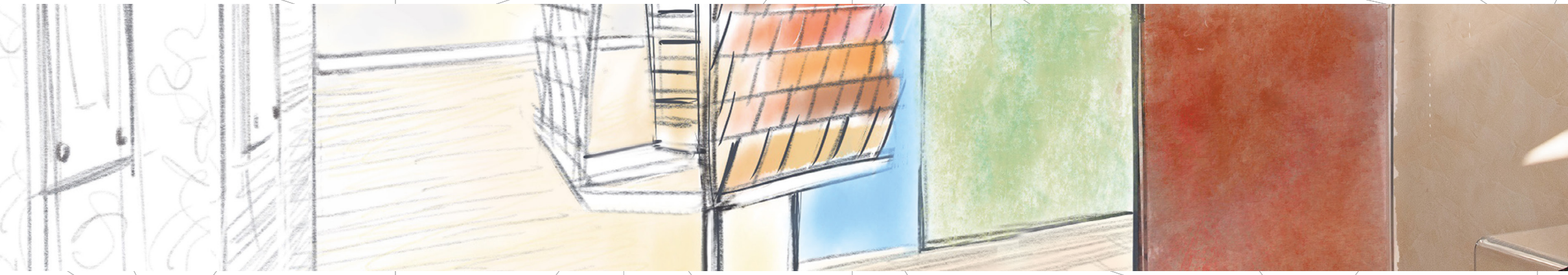

EMOTION

SOLUTIONS

VALUES

INVESTING
in the present
for a **future**
of **SUCCESS**

GAMMA
SERVIZI

IL PROGETTO

ADIHOME è un progetto innovativo, personalizzabile e dal forte impatto emozionale.

Presenta e valorizza la gamma completa dei prodotti Adicolor: decorativi e tradizionali.

Offre un sistema tintometrico rinnovato, potenziato, modulare e versatile.

Propone una varietà di servizi e soluzioni marketing e commerciali realmente straordinari.



RANGE
SERVICES

ADIHOME is an innovative and adaptable project of strong emotional impact.

It presents and enhances the full range of Adicolor products: decoratives and traditionals.

The project offers a totally renewed, advanced and versatile modular tinting system.

The proposal includes a variety of truly remarkable marketing services and business solutions.

THE PROJECT

Decorativi semplicemente creativi
 Decoratives simply creative

- Wool
- Desiré
- Desiré Luxury
- Marmi & Graniti
- Splendida
- Joyé
- Athelié
- Shadé S-L-R
- Amiré Light
- Velé
- Velé Silver & Gold
- SK
- Damaschi
- Sandé
- Veli&Velluti
- Venexian Faux
- Venysé
- Mizaar
- Marmorino
- Travertinus
- DecorDek
- Old Fashion
- Arenarya

23

Linee di prodotti decorativi

Lines of decorative products

CLIENTE...

ADIHOME è un progetto completo e di grande efficacia nel guidare il cliente alla scelta del colore e del prodotto più idoneo alle proprie necessità.

PER IL CLIENTE...

ADIHOME is a comprehensive and highly effective project aimed to guide customers in their choice of the ideal color and the most appropriate product to suit their need.

CLIENT...

FOR THE

1812

Finiture formulate a tintometro

Color formulations in the tinting system

1

Book Decorativi con prodotti applicati dal vero

Decorative Book with true product applications



Linea Tradizionali
Traditional Product Line

Idropitture Lavabili
Washable paints

Idropitture Traspiranti
Interior emulsion paints

Quarzi per esterno
External quartz paints

Trattamento Antimuffa
Antimould treatments

Smalti
Enamel paints

Protettivi per Legno
Wood Care

Stucchi
Putties

937

Colori di mazzetta
formulati a tintometro

*Fan-deck colors
formulated in the tinting
system*



Espositore da terra
per le 294 tessere

*Floor stand to display
the 294 sample color cards*



294

Tessere di colori reali "take away"
Individual "take away" sample color cards



∞

Finiture e Resine per pavimenti
e rivestimenti

*Finishes and Resins for floors
and walls*

PER IL PUNTO VENDITA

ADIHOME qualifica il Punto Vendita e ne favorisce la crescita perché interessa e coinvolge anche la fascia di mercato più professionale ed esigente.

ESPERIENZA sensoriale
SENSORY experience

ADIHOME is a concept that highly qualifies Points of Sale, promoting their growth by stimulating interest and encouraging even the most demanding professional segment of the market.

FOR THE POINT OF SALE





PROGETTAZIONE PERSONALIZZATA
 I nostri arredatori sono a disposizione per studiare e proporre una soluzione espositiva adeguata agli spazi disponibili e personalizzata in base alle specifiche esigenze del Punto Vendita.

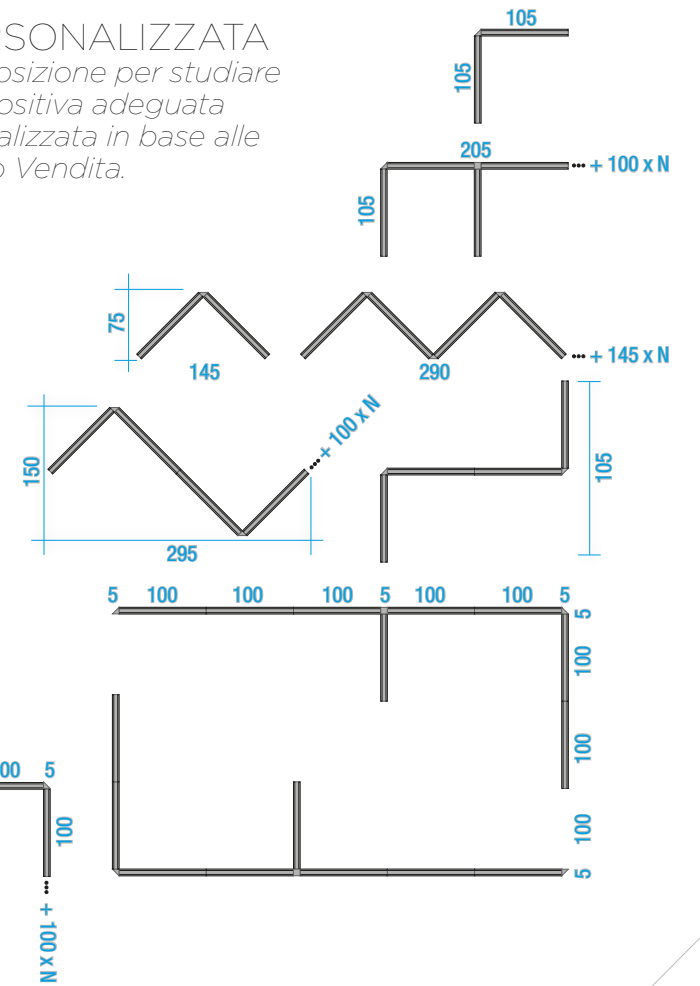

PERSONALIZED DESIGN
 Our experts are at your disposal to study a suitable proposal and customized plan in accordance with the available space and specific needs of each individual store.





COSA OFFRIAMO

Progettazione e realizzazione dello spazio espositivo

Fornitura del sistema tintometrico

Fornitura del materiale informativo e promozionale

Inserimento nelle campagne pubblicitarie aziendali

Supporto nelle iniziative marketing e commerciali sul territorio

Formazione ed assistenza nel tempo

Contatti con architetti, progettisti, arredatori ed altri professionisti del settore

*UN
PROGETTO
DI SUCCESSO
IN ESCLUSIVA*

*AN
EXCLUSIVE
PROJECT
OF SUCCESS*

The design and construction of the exhibition space

The supply of the tinting system

The supply of the descriptive and promotional material

Partaking in our advertising campaigns

Support in future marketing and sales initiatives in the area

Pre and post-sale training and assistance

Contact with architects, interior designers, decorators and other professionals in the field

OUR PROPOSAL



LE CARATTERISTICHE PER ESSERE ADIHOME

- Forti motivazioni ed entusiasmo
- Spazio adeguato per ospitare tutto o parte del progetto espositivo
- Personale qualificato e preparato in grado di presentare al meglio tutti gli aspetti estetici e funzionali che contraddistinguono i prodotti
- Capacità di gestire e sviluppare il rapporto professionale con architetti, progettisti, arredatori d'interno e più in generale con tutta la clientela, per la promozione dei prodotti Adicolor

insieme
SI cresce

THE FEATURES TO BE IN THE ADIHOME PROJECT

- Strong motivation and enthusiasm
- An adequate space to accommodate all or part of the exhibition project
- Qualified and well prepared personnel able to present the aesthetic and functional features that distinguish our products
- The ability to manage and develop a professional relationship with architects, interior designers, decorators and generally with all customers, to efficiently promote the sale of Adicolor products

together
we grow

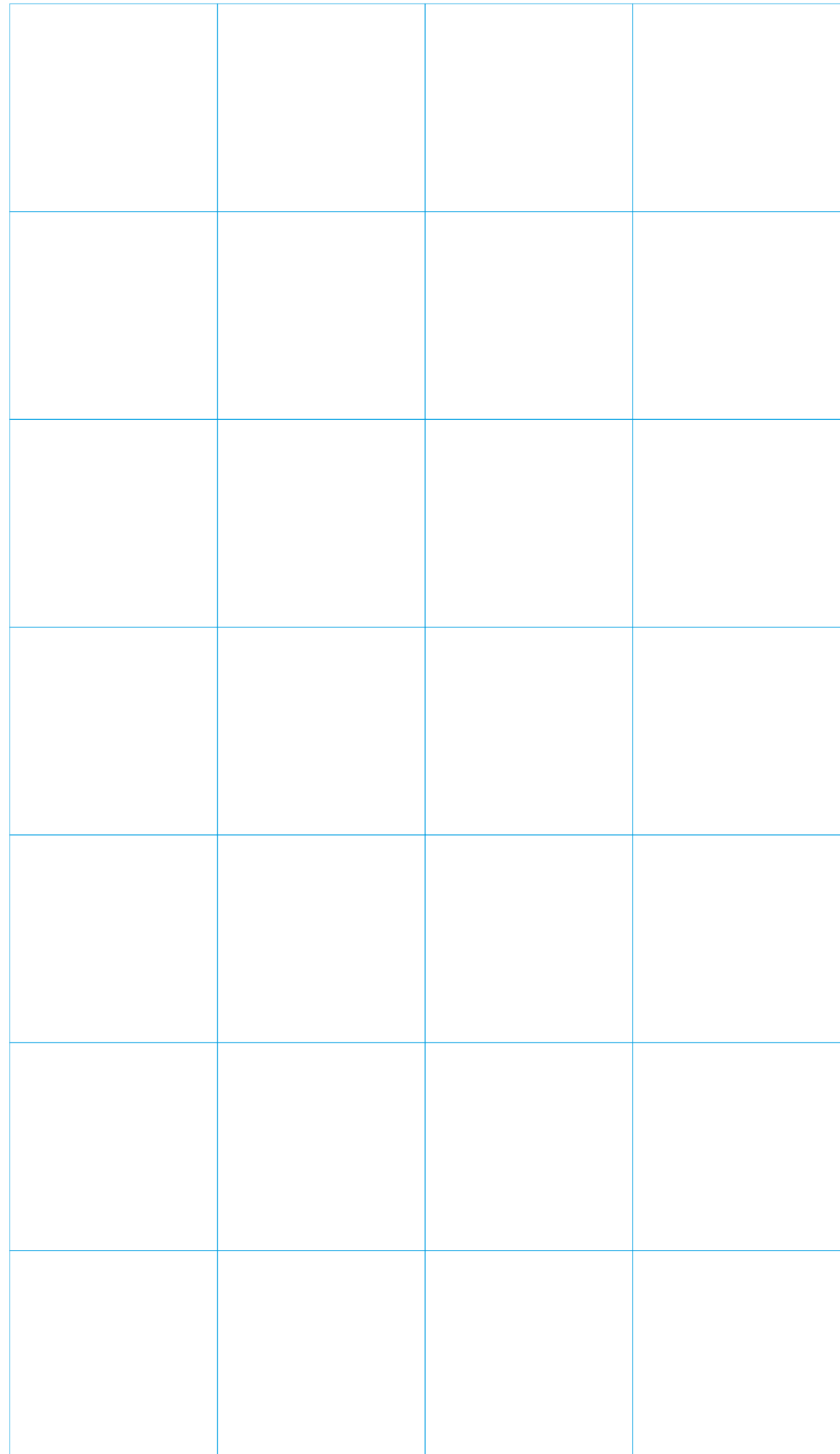

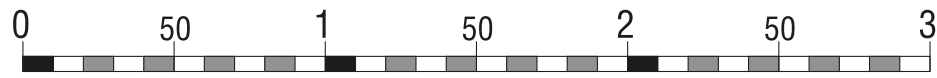

MODULI ESPOSITIVI
MODULAR ELEMENTS

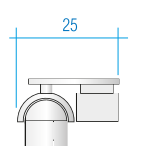
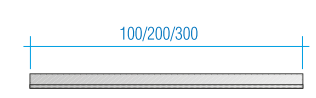
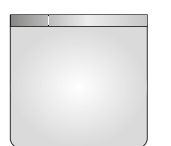
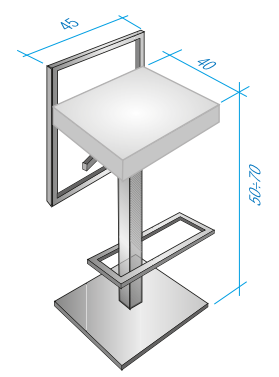
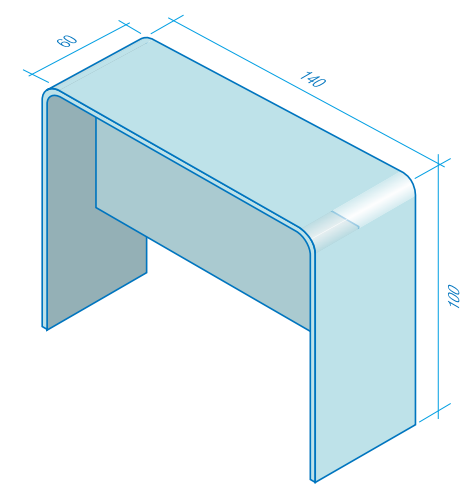
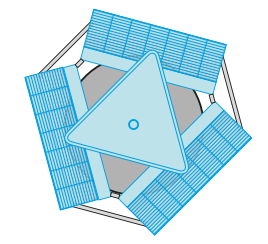
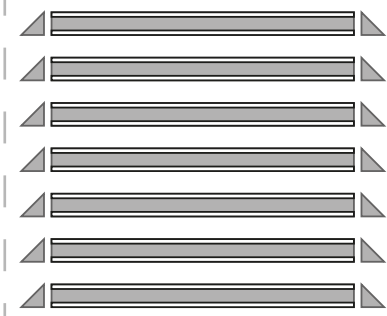
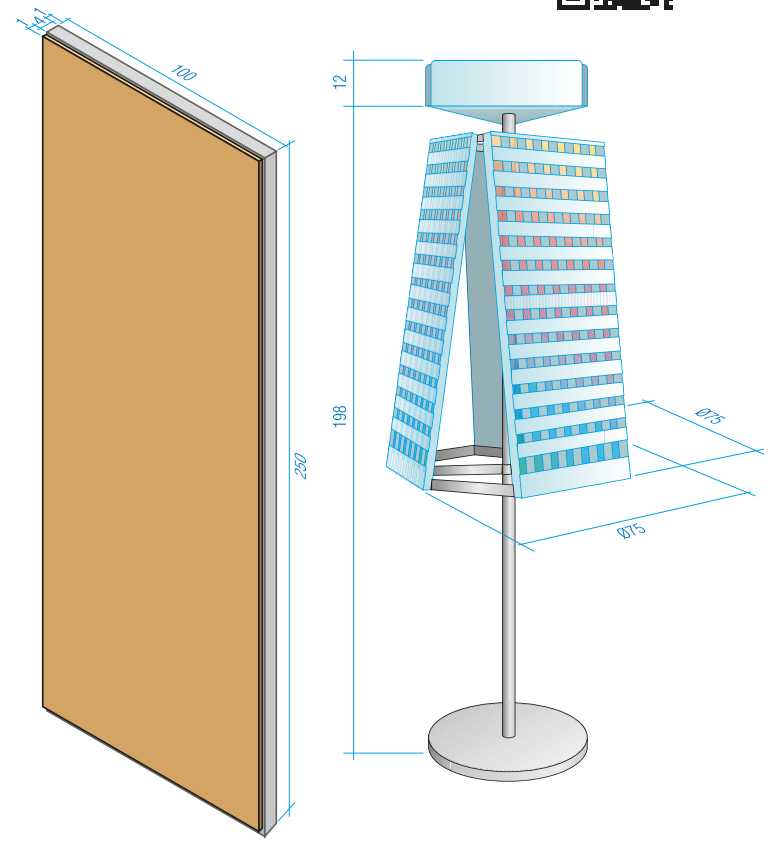
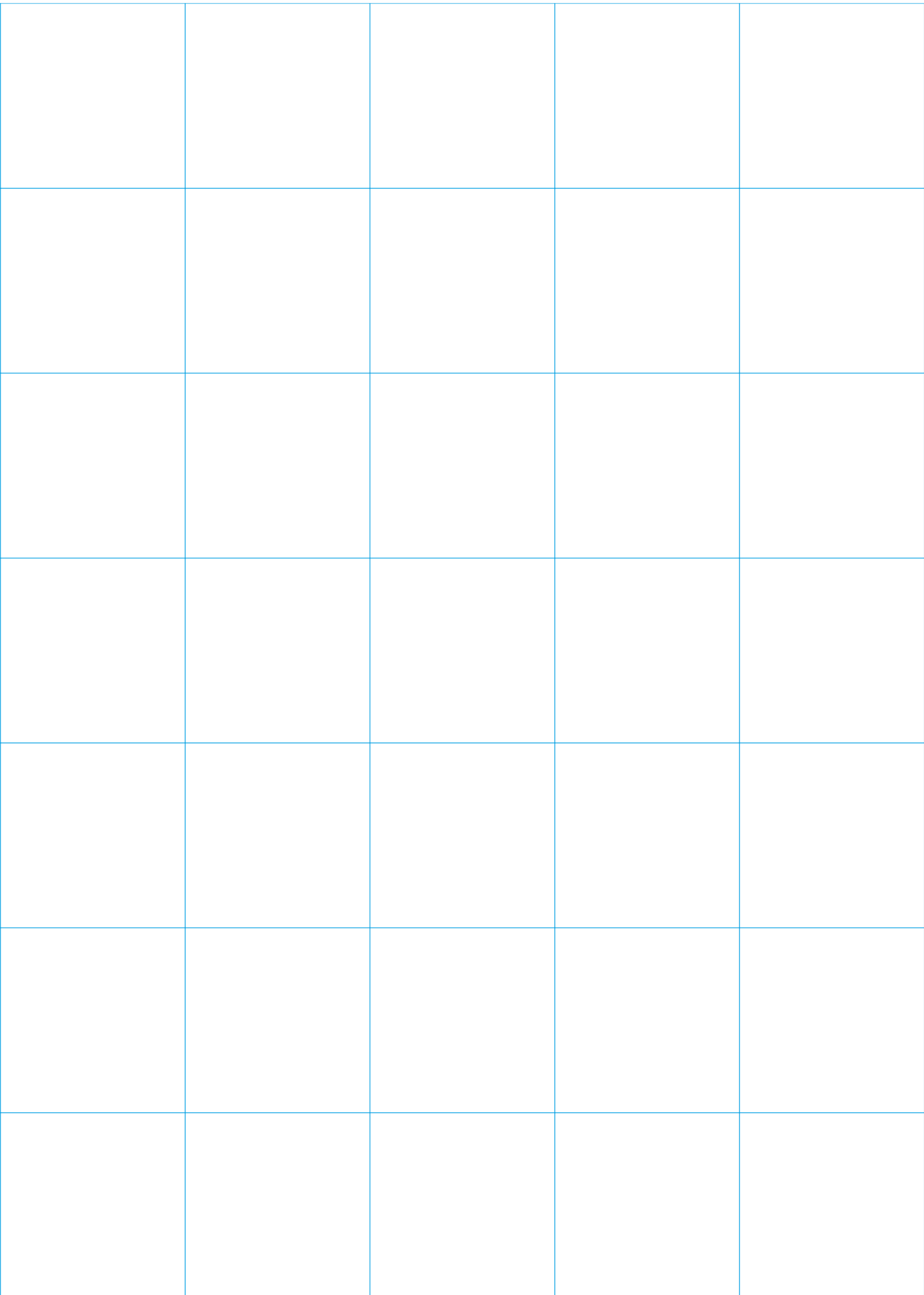



Genuine Italian Made

Adicolor s.r.l.
20060 Triginto di Mediglia (MI) - ITALY
Strada Provinciale 159, n. 2
Tel. +39 02 90 660 740 r.a.
www.adicolor.it - info@adicolor.it

*Azienda con sistema di qualità certificata
ISO 9001:2015 da Bureau Veritas Italia*